

October 4, 2004

Timothy O'Conner;

Thank you for inquiring about our products and services.

I want to express to you that Crossflow Aero Corp. is a state-of-the-art operation that manufactures very high quality aviation products. We've gone to great lengths to make sure all our processes meet Aerospace industry standard practices.

Here is the information you've requested:

▪ **Crossflow Propeller Speed Reduction Unit (PSRU) – US\$4,945.00**

- The Crossflow Aero Corp. Propeller Speed Reduction Unit (PSRU) is an internal spur gear reduction drive of proprietary design that had undergone 3 years of research and development. It has been specifically designed to work with Subaru automotive engines converted for aircraft use by our engineers. The PSRU employs some unique features that we believe make it the best choice on the market for Subaru based aircraft engines:
 - All internal drive components are CNC machined from 4340 certified Aerospace steel billet
 - Gears are nitrided using the controlled Nitreg process resulting in the formation of a hardened surface that reduces fatigue and wear together with improving resistance to seizure.
 - Internal bearings (angular contact and spherical rolling) are Aerospace quality
 - Gears are made to AGMA 10
 - Micro lash adjustment on housing for proper gear tolerances
 - Internal gear design allows for high contact tooth ratio with torque rating of 780 ft/lbs
 - Viton® oil seals to withstand temperatures up to 400°F
 - Anticorrosion nickel-plated prop flange drilled in SAE 1 & 2 or Continental bolt patterns
 - Custom built flywheel with built-in Sachs torsion damper
 - Gear lubrication by fully synthetic transmission fluid.
 - Built-in oil recirculator
 - Oil temperature probe and gauge incorporated
 - Drive can be used in either tractor or pusher configurations
 - Facility to install oil cooler, if required.

▪ **Specifications**

- **Reduction Ratio** **2.34 to 1**
- **Rotation** **Conventional**
- **Configuration** **Tractor or Pusher**
- **Weight** **60 lbs**
- **Length** **16"**
- **Offset** **1.625"**
- **Oil** **Full Synthetic Transmission fluid 1.6 litres**

Crossflow Propeller Speed Reduction Unit

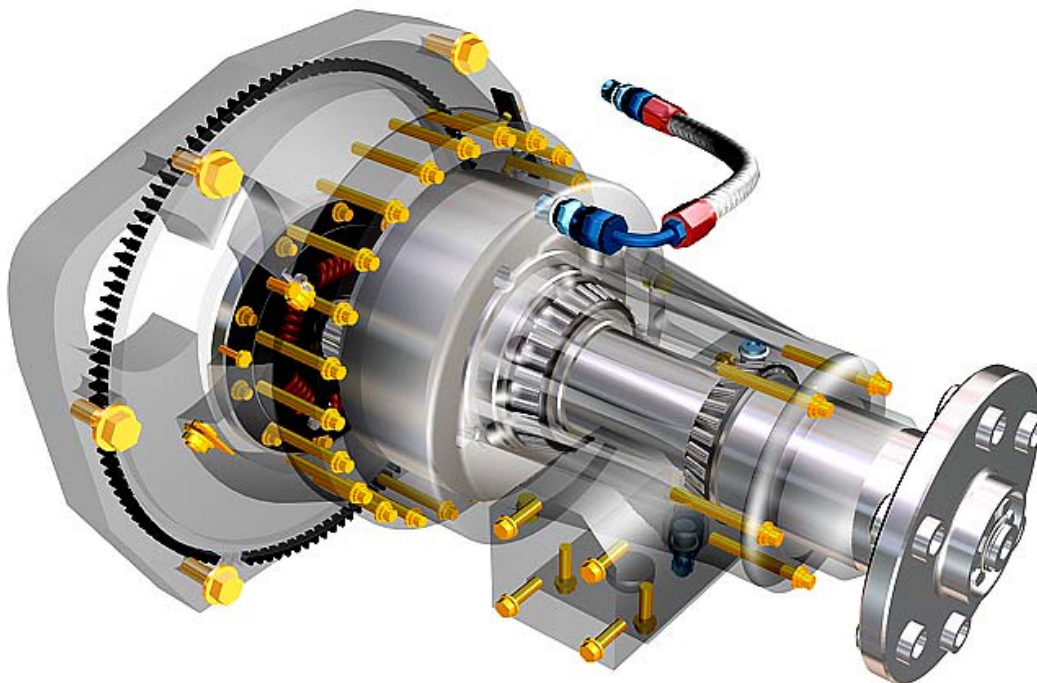
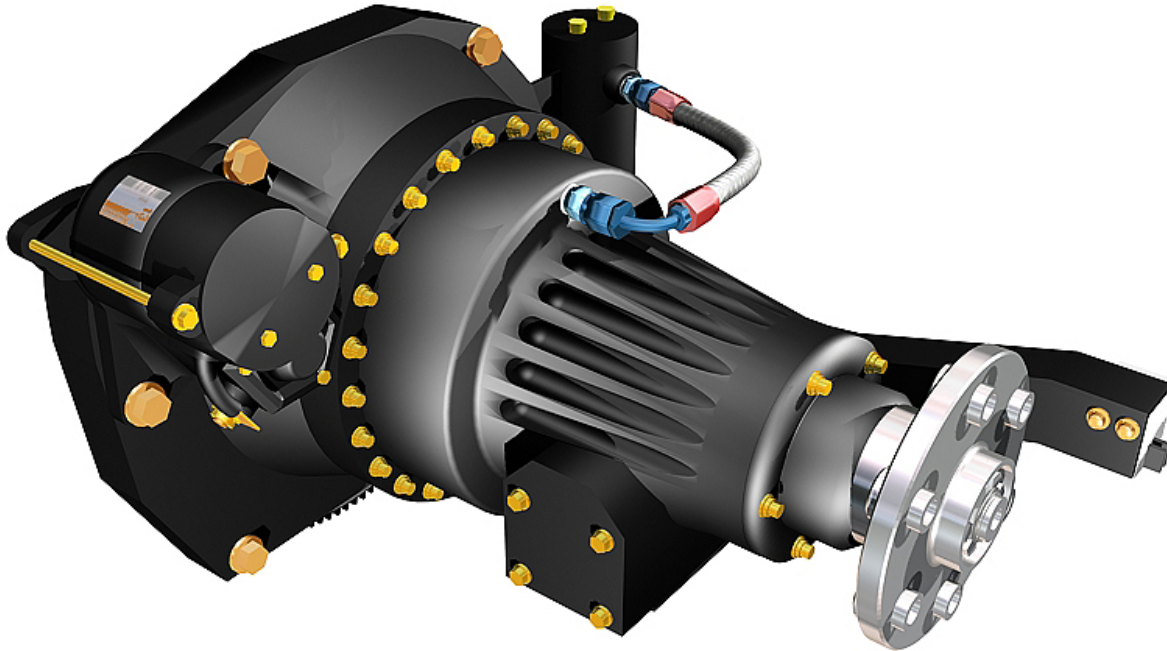

Crossflow Propeller Speed Reduction Unit

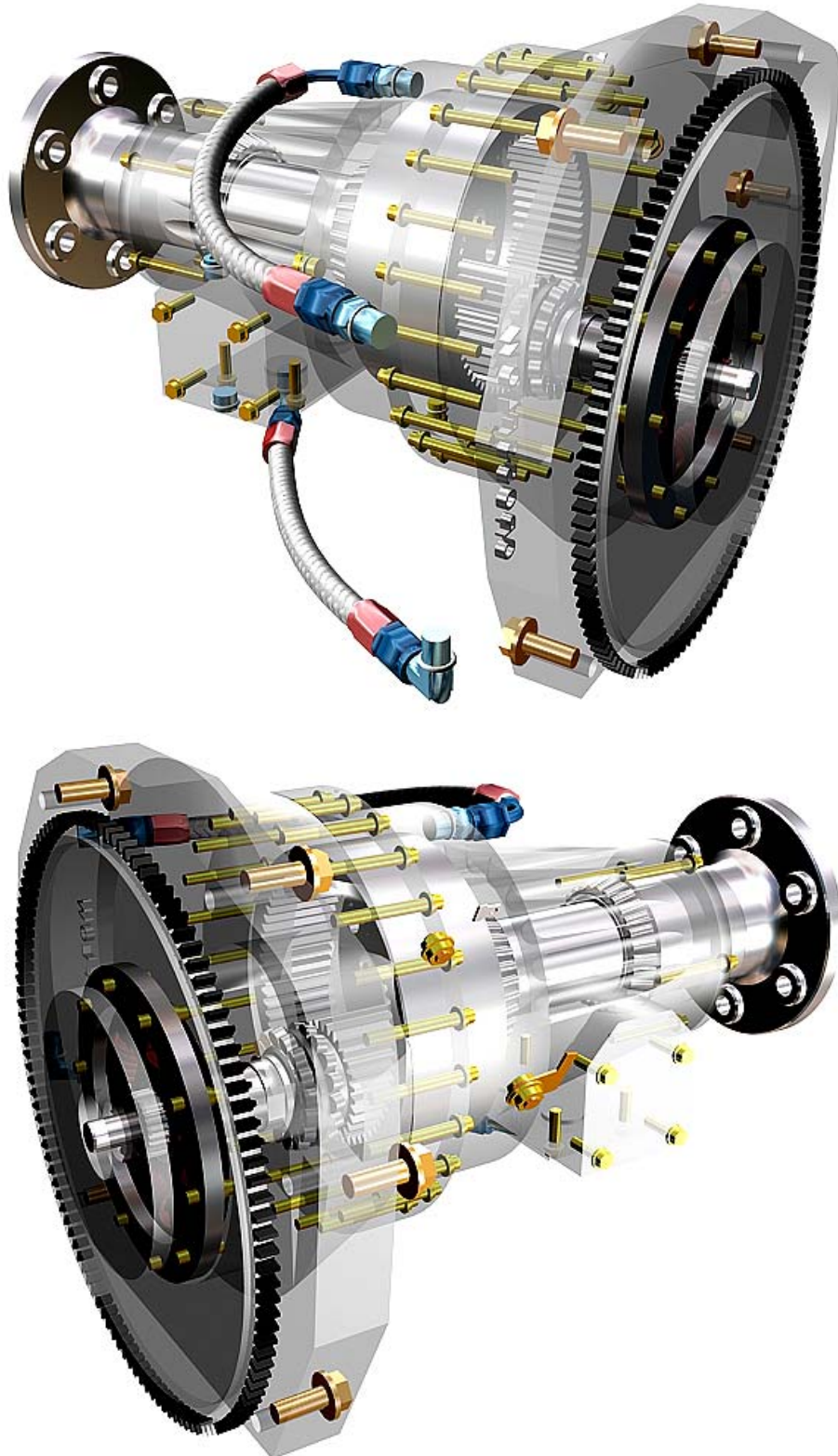



T 519.925.5255
F 519.925.5633
E info@crossflow.com
I www.crossflow.com

713 Industrial Road
Shelburne | Ontario
Canada | L0N 1S4

We also offer:

- | | |
|--|--------------------------|
| ■ Crossflow Inverted Flight Oil System - | US\$5,500.00 |
| ■ Crossflow PSRU Ancillary Drive Gears - | US\$1,293.75 |
| ■ Crossflow PSRU Hydraulic Collar - | US\$828.00 |
| ■ Crossflow Cabin Heating System - | US\$370.00 |
| ■ Crossflow Secondary Fuel Pump - | US\$460.00 |
| ■ Wiring Harness (hot and cold side of firewall) - | US\$2035.00 |
| ■ Engine Control Unit - | US\$1949.00 |
| ■ Engine Management System - | COMING SOON |
| ■ Custom Engine Mount and Cradle - | Depending on application |
| ■ Custom Exhaust/Cooling Systems (coated, stainless steel) - | Depending on application |

Our products are of the highest quality and come with a 12 month warranty commencing with the date of shipment.

I look forward to hearing back from you soon about your purchase thoughts on Crossflow Products. Please feel free to contact me if you have any further questions.

Sincerely,

Anna Muth
Crossflow Aero Corp.
519.925.5255 ex.200
anna@crossflow.com
www.crossflow.com